

ASTRO-G Mission in 2012

Dual pol. @ 8, 22, 43 GHz
Phase-referencing capability
Switching Maneuver
10 cm Orbit Determination

9.3 m Antenna with high surface accuracy (0.4mm rms)
precision pointing (0.005deg)

1 Gbps Data Downlink

Target Life Time is 3 years.

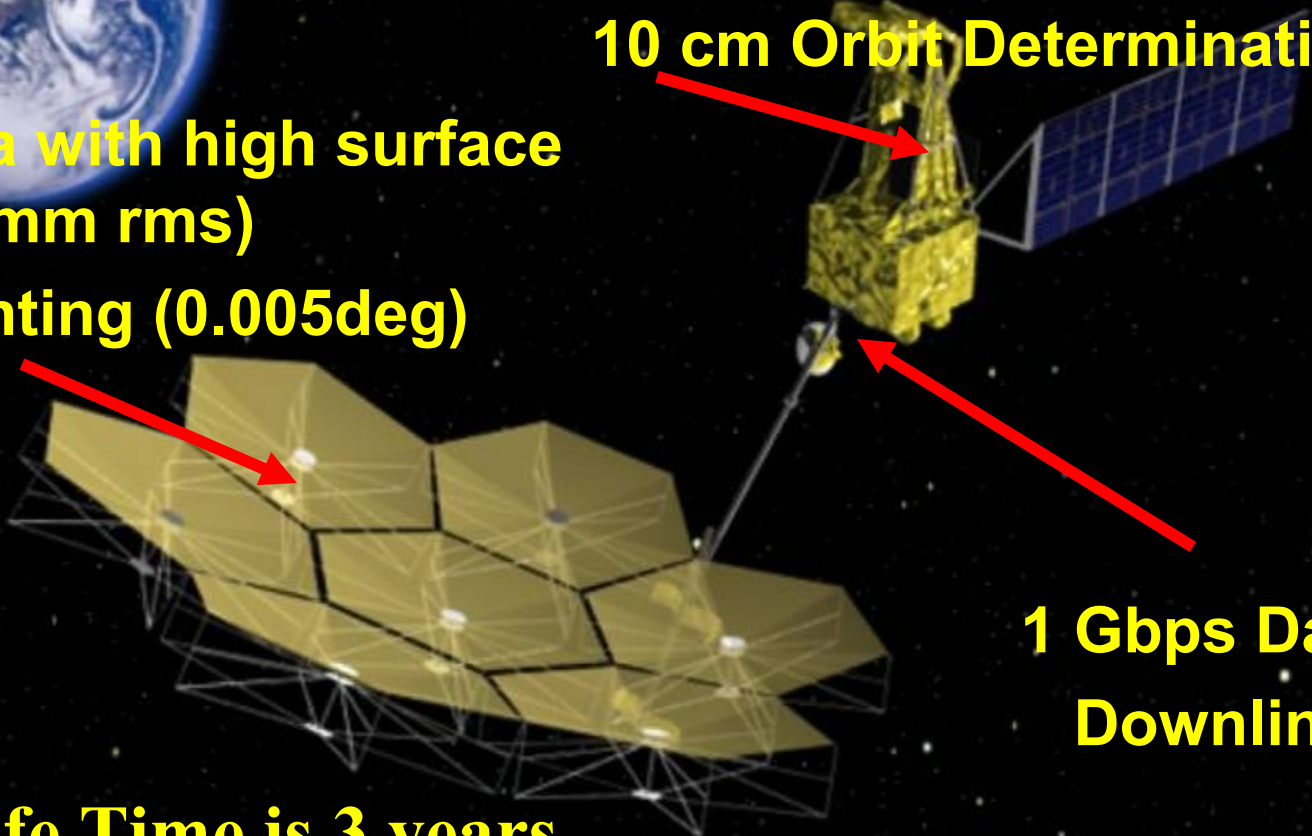

Why we are here?

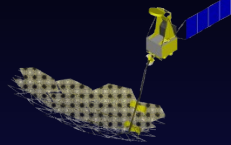

1. EVN (+ Global) covers most of the VLBI stations, except for Japan, Korea, Australia ...
2. Japanese and Korean status
 - Japanese and Korean co-deleping KVN, and KJJVC (Korean and Japan Joint VLBI correlator).
 - VSOP-2/ASTRO-G Tracking station design (Output is VSI-H).
 - KVN : Mark5B
 - Japanese Tracking station (Mark5B)
 - KJJVC accepts, Mark5(B), VERA terminal, eVLBI?, and K5/VSI.
3. Know the detailed but important problems for operating (gigabit) VLBI.
4. I/F 's GRT's to SVLBI correlators, and Tracking Stations to European correlators.

VSOP-2 Interface Control -Ground system-

National Astronomical Observatory of Japan
Yusuke Kono

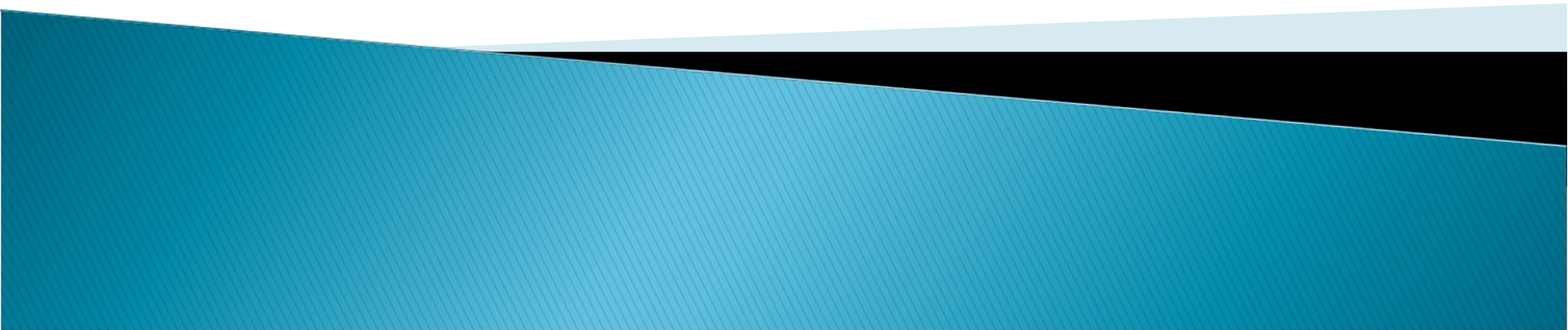

Interface between ground network and VSOP-2 project

- ▶ The designs of the satellite and a tracking station almost fixed
- ▶ For successful VSOP-2 observation, interface to ground network is important



Interface point

VSOG2 (TBD)
Operation/Scheduling

Satellite
Observation

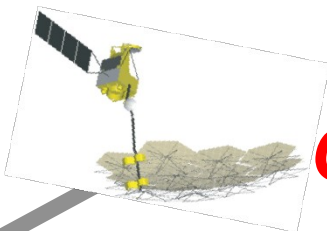

Tracking Station

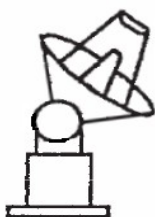

Link SYSTEM

Station System



dT, etc



Terminal

Ground Network

Correlator



GRT

Observation

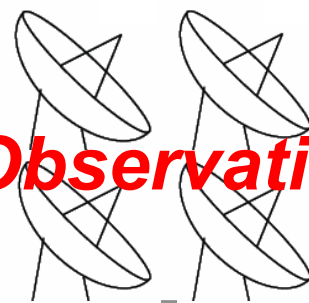

dT, etc



Terminal



Observation Interface (Table1)

Frequency range	Q-band (L) : 41-43.18 GHz Q-band (H) : 43-45 GHz K-band : 20.6-22.6 GHz X-band : 8.0-8.8 GHz
Polarization	RHCP and LHCP
Band and polarization selection	See Table 2
System noise temperature (typical)	Q-band : 61 K-band : 37 X-band : 88
Side band of mixers and ADC	DC of Q-band (L/H) □□□□□ : USB DC of K-band □□□□ : LSB DC of X-band (=BBC) □□ : USB BBC (Base Band Convertor) □ : USB ADC □□□□ : USB
Frequency selection step of BBC	32 MHz
Number of baseband channel	2 channel
Bandwidth and quantization	1) BW 128 MHz-2bit-2ch 2) BW 256 MHz-1bit-2ch
Amplitude flatness in frequency band	2dB pp (Maximum)
Frequency switching capacity	Available (Within 10 seconds, TBD)
Antenna switching capability	Available (Minimum switching period is 1minute for 2.8 deg separation angle; The maximum slewing speed is 2.8deg/15sec)
Amplitude calibration capability	Available by the power meters.

Interface point

VSOG2 (TBD)
Operation/Scheduling

Satellite

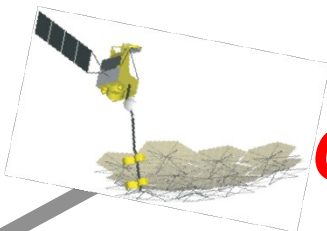

OBS

Tracking Station

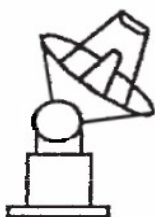

Link SYSTEM

Station System



dT, etc



Terminal

Ground Network

Correlator



GRT



OBS

dT, etc



Terminal



Terminal

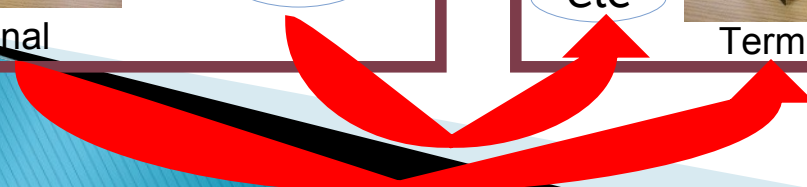

Demodulator output

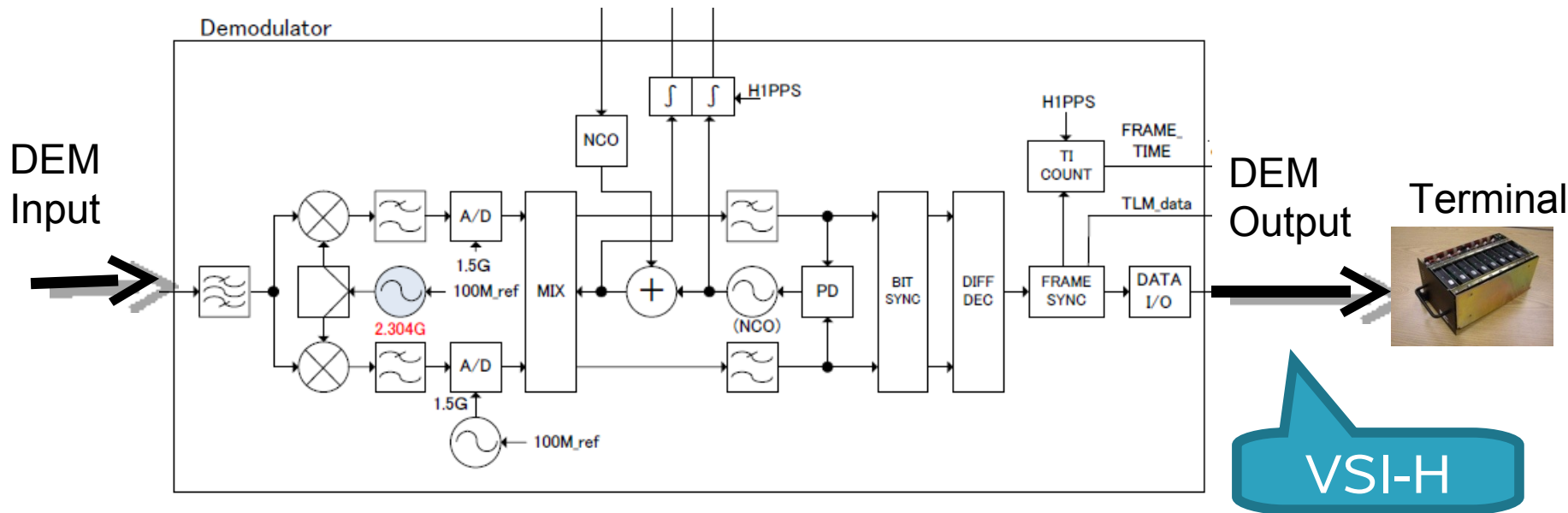

Candidates of VLBI terminal with VSI-H
Mark5B ,K5, RVDB,,,

=> Mark5B

Terminal Selection : Mark5B

Conditions of selection

3.Compatibility to correlators

5.Portability

7.Readiness

EAVN Correlator



Mk5B acceptable

EVN Correlator



Mk5B acceptable

VLBA Correlator



Mk5B acceptable (Mark5B emulation mode of Mark5C)

VSI Output from DEM

Interface	VSI-H rev 1.0
Mechanical interface	MDR 80 pin connector
Electrical interface	LVDS
Number of channel	1
Clock rate	32MHz
Signals	DATA:32 bit Clock: Defined by VSI-H specification 1PPS: Defined by VSI-H specification VALID: Defined by VSI-H specification QDATA: Time code of 115.2 kbps serial data. ADS-1000 QDATA compatible.

Pin allocation (VSI-H)

MDR80pin
connector pin
allocation

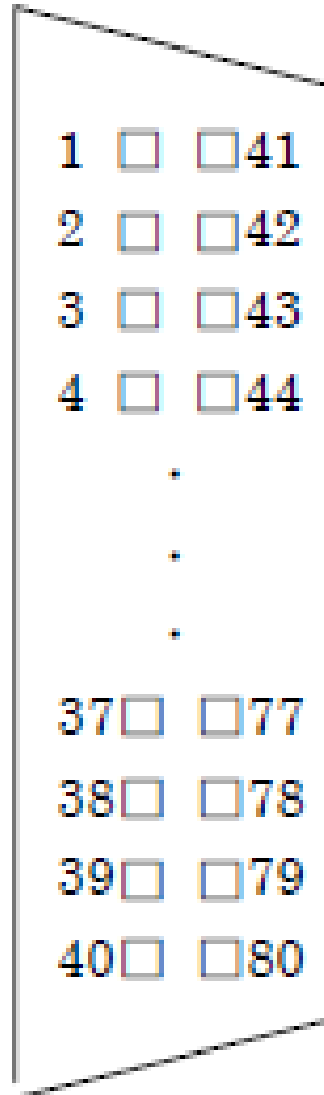

PIN	SIGNAL	IN/OUT	PIN	SIGNAL	IN/OUT
1	BSp[0]	IN	41	BSn[16]	IN
2	BSn[0]	IN	42	BSp[16]	IN
3	BSp[1]	IN	43	BSn[17]	IN
4	BSn[1]	IN	44	BSp[17]	IN
5	BSp[2]	IN	45	BSn[18]	IN
6	BSn[2]	IN	46	BSp[18]	IN
7	BSp[3]	IN	47	BSn[19]	IN
8	BSn[3]	IN	48	BSp[19]	IN
9	BSp[4]	IN	49	BSn[20]	IN
10	BSn[4]	IN	50	BSp[20]	IN
11	BSp[5]	IN	51	BSn[21]	IN
12	BSn[5]	IN	52	BSp[21]	IN
13	BSp[6]	IN	53	BSn[22]	IN
14	BSn[6]	IN	54	BSp[22]	IN
15	BSp[7]	IN	55	BSn[23]	IN
16	BSn[7]	IN	56	BSp[23]	IN
17	BSp[8]	IN	57	BSn[24]	IN
18	BSn[8]	IN	58	BSp[24]	IN
19	BSp[9]	IN	59	BSn[25]	IN
20	BSn[9]	IN	60	BSp[25]	IN
21	BSp[10]	IN	61	BSn[26]	IN
22	BSn[10]	IN	62	BSp[26]	IN
23	BSp[11]	IN	63	BSn[27]	IN
24	BSn[11]	IN	64	BSp[27]	IN
25	BSp[12]	IN	65	BSn[28]	IN
26	BSn[12]	IN	66	BSp[28]	IN
27	BSp[13]	IN	67	BSn[29]	IN
28	BSn[13]	IN	68	BSp[29]	IN
29	BSp[14]	IN	69	BSn[30]	IN
30	BSn[14]	IN	70	BSp[30]	IN
31	BSp[15]	IN	71	BSn[31]	IN
32	BSn[15]	IN	72	BSp[31]	IN
33	1PPSp	IN	73	N.C.	—
34	1PPSn	IN	74	N.C.	—
35	N.C.	—	75	PDATA _n	IN
36	N.C.	—	76	PDATA _p	IN
37	PVALID _p	IN	77	N.C.	—
38	PVALID _n	IN	78	N.C.	—
39	CLOCK _p	IN	79	N.C.	—
40	CLOCK _n	IN	80	N.C.	—

Data Format (proposal, same as KJJVC)

Data format (2bit-128MHzBW-2ch)

CH A														CH B																	
M	L	M	L	M	L	M	L	M	L	M	L	M	L	M	L	M	L	M	L	M	L	M	L	M	L	M	L				
0	0	1	1	2	2	3	3	4	4	5	5	6	6	7	7	0	0	1	1	2	2	3	3	4	4	5	5	6	6	7	7

Bit
0

Bit

Data format (1bit-256MHzBW-2ch)

31

CH A															CH B																
0	1	2	3	4	5	6	7	8	9	10	11	12	13	14	15	16	17	18	19	20	21	22	23	24	25	26	27	28	29	30	31

Sample code of 2bit

Signal level	Sample code (EAVN/Mk5B)	Sample code (Mark5C)
>Threshold	11	01
0 ->Threshold	10	00
0 -> neg.Threshold	01	11
<neg. Threshold	00	10

TIME CODE: EAVN P-DATA format

#	VSI	,	TIM	,	SP	,	CLK	,	SP	,	Test	,	VP	,	VP	;	C	R
	ID		E		F		Freq		B		pattern		1		2		R	

TIME is required for KJJVC. The format of TIME is YYYYDDDDHHMMSS. VSI ID, SPF, CLK SPB, Text pattern, VP1 and Vp2 are optional for KJJVC. The length from the first delimiter “#” to the final “CR” must be shorter than 2028 Byte.

Mark5B DATA Frame Header

	Bit 31		Bit 0
Word 0	Sync word (TBD)		
Word 1	Years from 2000	User-specified data	T Frame# within second (starting at 0)
Word 2	VLBA BCD Time Code Word 1 ('JJSSSS')		
Word 3	VLBA BCD Time Code Word 2 ('.SSSS' plus 16-bit CRCC)		

Table 6: Disk Frame Header format

Mark5B under test at NAOJ

- ▶ EM test start with link station modules this year
 - ▶ problem
 - ▶ Clock changes due to Doppler
 - ▶ $32\text{MHz} \pm 800\text{Hz}$ (7km/s)
 - ▶ Under test now in NAOJ
 - ▶ OK : +800Hz

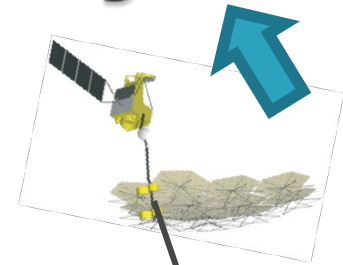

The first Mark5B terminal at Mitaka in 2008

Future works

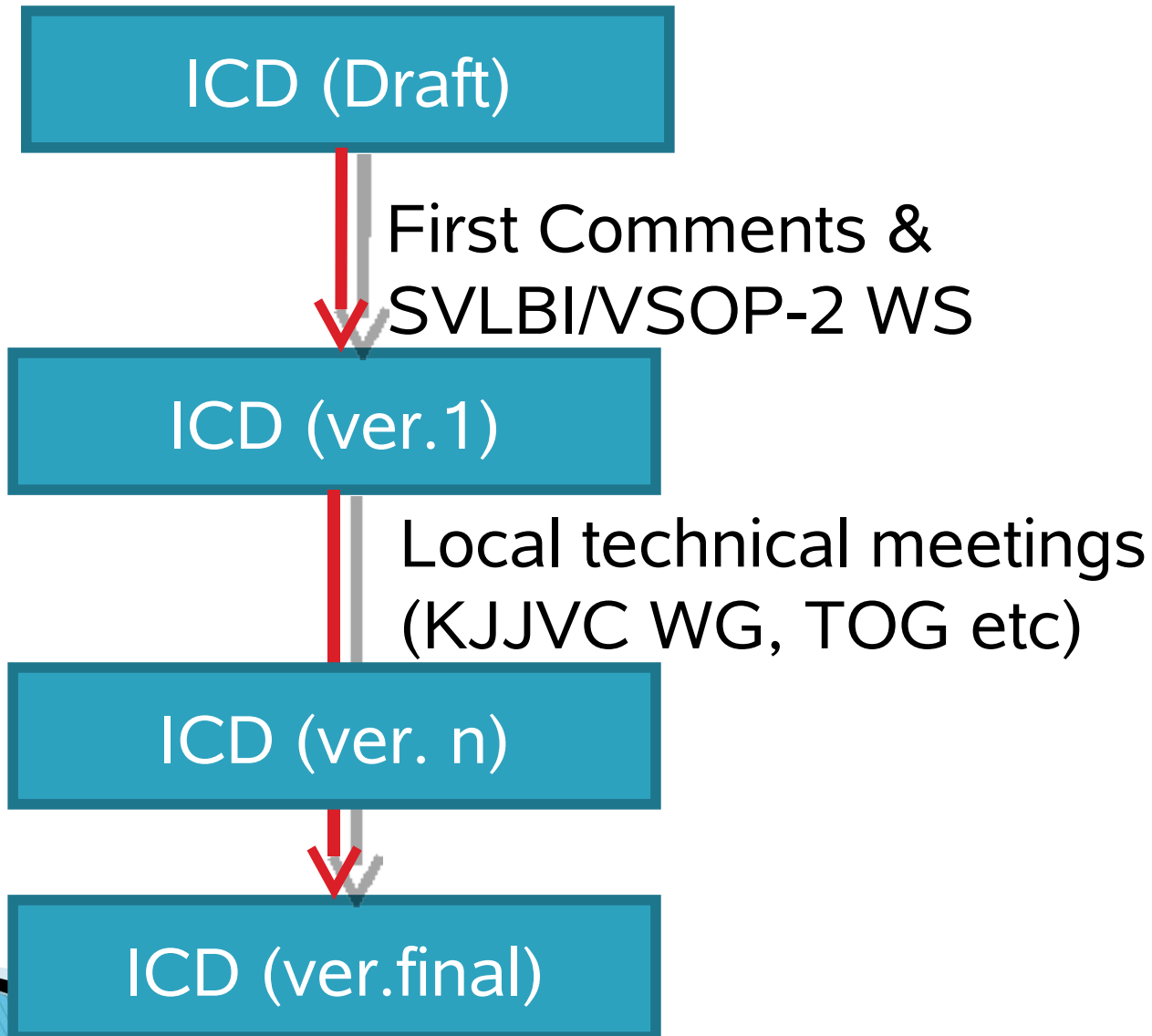

Global VLBI participation

- ▶ Global VLBI observations strengthen VSOP-2 project
- ▶ Pre-launch observation?
 - Japanese telescope candidates (my opinion)
 - ◻ Nobeyama 45m (22, 43GHz)
 - ◻ Kashima 34m (8, 22, 43GHz)
 - ◻ Yamaguchi 32m (8,22GHz)
- ▶ VLBI terminal is Mark5B.
 - Data recorded at stations can be copied to Mark5B at NAOJ
- ▶ Pre-launch obs. is important
 - We hope for collaborators

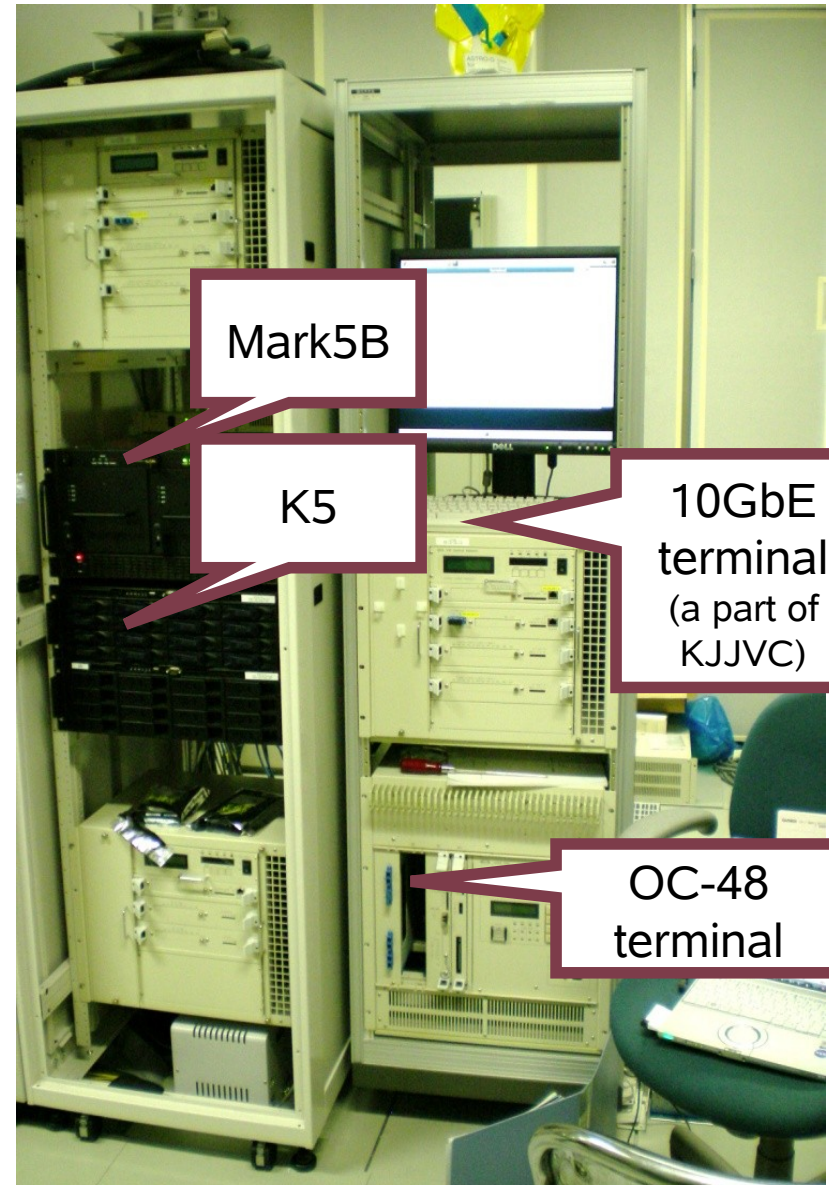

Thank you!

International meetings **International Activities**

– Tracking station meetings (5 times)

- #1 @ JPL Pasadena, Nov. 2006
- #2 @ Yebees Spain, Feb. 2007
- #3 @ Sagamihara, Apr. 2007
- #4 @ Greenbank, Aug. 2007
- #5 @ Sagamihara, Dec. 2007 “Agreed c



– Japan-U.S. KSP (Key Science Program) Meeting Oct 19-21 @ Mitaka

– VSOP-2 symposium (Dec 3-7, 2007 @ Sagamihara)

- 135 participants. Half from outside of Japan (13 countries)

– VSOP-2 Science Meeting (May 14-16, 2008 @ Bonn)

– First VISC-2 Meeting (May 13, 2008 @ Bonn)

• Proposals

– SAMURAI proposal (submitted in Jan., NOT accepted @ June 20, 2008)

- Proposal to NASA Mission of opportunity for US VSOP-2 supports (Tracking station, VLBA, JPL project office and navigation. See. NRAO report)
- Received good peer review report, but does not succeeded.
- Investigating other plans.

– European Proposals

- FP7 SPIRIT
- ESA Nationally Led proposal (Tracking station, SVLBI use of GRT, Correlators). ---- won't happen in 2008. Investigating other options